

HCR 120-EDs III

FRD
FURUKAWA

HYDRAULIC CRAWLER DRILL

EPA Tier 3 / EU Stage III A

To achieve more powerful and speedy drilling

Wide covering Extension boom

- ✓ High-power Drifter HD712
 - Highly-efficient percussion system
 - Dual damper system
- ✓ Hole diameter 76 mm-115 mm
- ✓ Safety ROPS/FOPS cabin
- ✓ Advanced rod changer
- ✓ Powerful track



FRD FURUKAWA ROCK DRILL



■ Dimensions (mm)

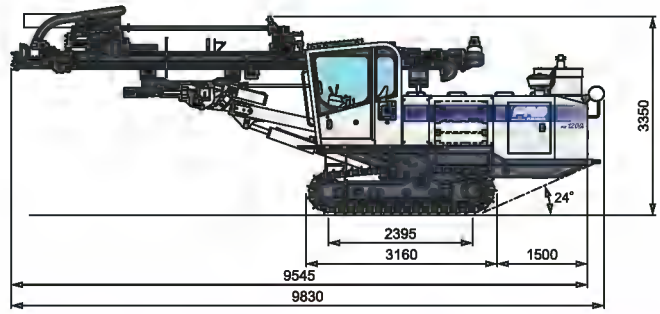
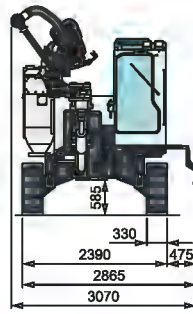

■ Specifications

Model	HCR1200-EDS III
Dimensions & Weight	
Operating Weight (A) *1	12,830 kg
Overall Length	9,830 mm
Overall Width (Shipping)	3,070 mm (2,400 mm)
Overall Height (Shipping)	3,350 mm (3,045 mm)
Drifter	
Model	HD712
Weight	230 kg
Number of Blows	2,250 ~ 2,500 min ⁻¹
Undercarriage	
Track Length	3,160 mm
Track Length on Ground	2,395 mm
Track Width	330 mm
Ground Pressure *2	79.6 kPa
Ground Clearance	585 mm
Frame Oscillation Angle	± 7.5°
Tramming Speed	0 ~ 3.2 km/h
Gradeability	57.7 % (30°)
Maximum Traction Force	88 kN
Engine	
Model	C7 (EPA Tier3, EU Stage IIIA)
Type	Diesel, Water-cooled, 6cylinders
Make	CATERPILLAR
Power Output	168 kW / 2,200 min ⁻¹
Fuel Capacity	320 L
Hydraulic Equipment	
Variable Displacement PV Pump	PV Pump x 2
Fixed Displacement Pump	Gear Pump x 3
Hydraulic Oil reservoir Capacity	170 L
Boom	
Model	JE326
Type	Extension Boom
Boom Lift Angle	Up 45°, Down 15°
Boom Swing Angle	Right 30°, Left 4°
Boom Slide Length	900 mm

Model	HCR1200-EDS III
Guide Shell	
Model	GH831
Length (12 feet)	7,825 mm
Feed Length (with Reverse Percussion)	4,736 mm (4,561 mm)
Feed Type	Hydraulic motor driven chain
Guide Slide Length	1,200 mm
Guide Swing Angle	Right 30°, Left 90°
Guide Tilt Angle	180°
Maximum Rod Pull-Out Force	31.4 kN
Compressor	
Model	PDS265-S35C
Type	1 Stage screw compressor
Free Air Delivery	7.1 m ³ /min
Discharge Pressure	1.03 MPa
Dust Collector	
Model	A884-231
Suction Capacity	26 m ³ /min
Number of Filter Element	5
Type of Dust Ejection	Automatic air pulse jet
Rod Changer	
Model	GR180
Number of Rod Storage	5 (45R) / 4 (51R)
Rod Length	3,660 mm
Bit and Rod	
Bit Range	76 ~ 102 (115) mm
Rod Diameter	45R, 51R
Rod Length	3,660 mm (12 feet)
Maximum Starter Rod Length	4,270 mm
Electrics	
Battery	12V; 108Ah/5h
Light	24V; 70W × 4
Voltage	DC24V
Operating Environment	
Environmental Temperature	-15 °C ~ +45 °C

Note: *1 "Operating Weight (A)" includes weight of fuel and oils (full) *2 "Ground Contact Pressure" is calculated on "Operating Weight (A)".

■ Vertical Drilling Coverage (mm)

● HCR1200-EDS III

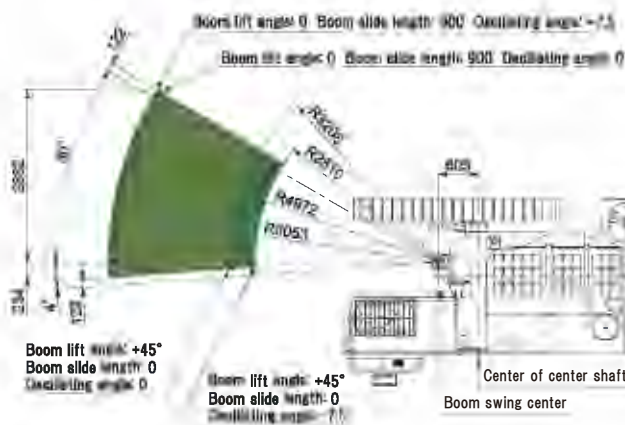

● HCR1200-DS III

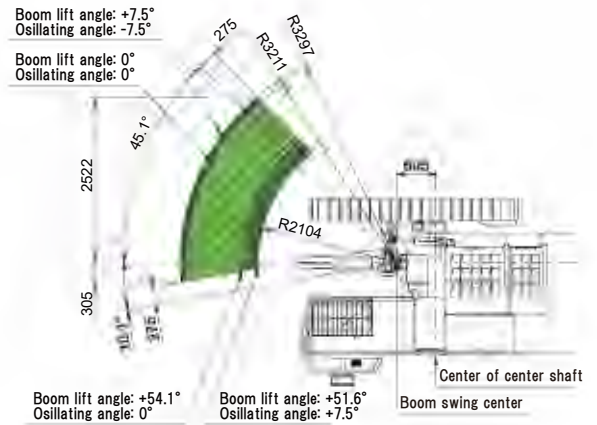

FRD FURUKAWA ROCK DRILL CO.,LTD.

2-6-4, Otemachi, Chiyoda-ku, Tokyo 100-8370, Japan
Phone +81-3-6636-9521 Fax +81-3-6636-9555

<https://www.furukawa-rockdrill.com/>

The contents of this specifications are subject to change without notice in the future.

HCR1200-EDS III -E2205-F1